



## Agilent PN 4294A

# New Technologies For Accurate Impedance Measurement (40Hz to 110MHz)

Product Note

Page	Contents
1	1. Introduction
2	2. Comparison of Previous Impedance Measurement Techniques
3	3. Features of the Auto-Balancing-Bridge Technique
4	4. Problems with Previous Auto-Balancing-Bridge Technique
6	5. Agilent 4294A Solution No. 1: Frequency Expansion
8	6. Agilent 4294A Solution No. 2: Impedance/Phase Accuracy Improvements
10	7. Other New Technology—1: New Impedance Probe
11	8. Other New Technology—2: 7-mm Connector Adapter
11	9. Other New Technology—3: Cable Extension
12	10. Comparison of the Latest Impedance Measurement Techniques
12	11. Summary



### 1. Introduction

As the operational frequency and quality of electronic components and materials increases, an impedance measurement instrument with a wide frequency range and an exceptional accuracy is required for adequate electrical evaluation.

The Auto-Balancing-Bridge method (ABB) is widely used for Low-Frequency (LF) impedance analysis. This technique has many advantages such as exceptional measurement accuracy and a wide impedance measurement range, but it is limited in its frequency coverage.

In this product note, new technologies used in the Agilent Technologies 4294A Precision Impedance Analyzer are discussed. This impedance analyzer has extended the frequency range of the ABB technique, and provides new possibilities for LF impedance measurement. The new Auto-Balancing-Bridge method is explained in this product note.



**Agilent Technologies**

Innovating the HP Way

## 2. Comparison of Previous Impedance Measurement Techniques

Table 1 shows the major impedance measurement techniques as well as the previous frequency ranges covered. The Auto-Balancing-Bridge method provides the best measurement accuracy and broadest impedance coverage, thus permitting its use in all impedance measurement applications in the LF frequency range. The I-V method provides unique features in that it can perform measurements on a grounded device, as well as probe components in a circuit. However, the impedance measurement range and lower frequency range are limited when compared with the Auto-Balancing-Bridge method.

The RF I-V method is an enhanced I-V method, which successfully expands the frequency range to the GHz region. This method is suitable for a broad set of applications in the RF frequency range. The method, used by network analyzers, obtains impedance parameters from reflection coefficient measurements.

It is the only technology that can measure at high frequencies (microwave), but the accurate impedance measurement range is limited to those impedance values that are close to the characteristic impedance of the analyzer.

In general, applications requiring impedance measurement, such as component and material evaluation, utilize the ABB technique in the LF frequency range, while the RF I-V technique is used in the RF frequency range. Many DUTs (Devices Under Test), including capacitors and inductors, exhibit an impedance dependency as a function of frequency. In such cases, a measurement instrument with wide frequency coverage is required. As the frequency coverage of these various techniques increases, the impedance accuracy and impedance measurement range must be maintained. Given the history of these techniques, innovation of the ABB technique required that the frequency range be expanded in the 4294A.

**Table 1: Comparison of previous impedance measurement techniques**

Technology	Advantage	Disadvantage	Frequency range	Application
<b>Auto-Balancing-Bridge</b>	Most accurate Wide impedance measurement range Wide frequency coverage	Limited frequency coverage	5 Hz–40 MHz	All impedance measurement applications in LF (4194A, etc.)
<b>I-V</b>	Grounded device measurement Probing measurement	Limited frequency and impedance measurement range	10 kHz–100 MHz	In-circuit impedance measurement (4194A + 41941A, etc.)
<b>RF I-V</b>	Accurate impedance measurement through the GHz range Grounded device measurement	Limited frequency coverage	1 MHz–1.8 GHz	Components and materials measurement in RF (4291B, etc.)
<b>Network analysis</b>	Very broad frequency coverage (LF through microwave)	Impedance measurement range is limited to values close to the characteristic impedance of the analyzer.	$\geq 10$ kHz	Components and materials measurement (8753E, E5100, etc.)

### 3. Features of the Auto-Balancing-Bridge Technique

Figure 1 shows the circuit diagram of the Auto-Balancing-Bridge method. In order to perform precise impedance measurements, the voltage applied to the DUT, and the current, which flows through the DUT, need to be accurately measured. The voltage applied to the DUT is detected as “V1” at the High-Potential (Hp) terminal of the instrument. The terminal is isolated from the High-Current (Hc) terminal, which is a signal output terminal. This isolation enables accurate detection of the voltage applied to the DUT. The current, which flows through the DUT, goes to the Low-Current (Lc) terminal. If there exists a certain potential at the Lc terminal, stray capacitance between the terminal and ground is generated, and current may flow to ground. To avoid this, the LOW terminal is kept near the voltage level of ground. This is called a “Virtual Ground”, and it is functionally dependent on a feedback loop. The feedback loop is called a “null-loop.”

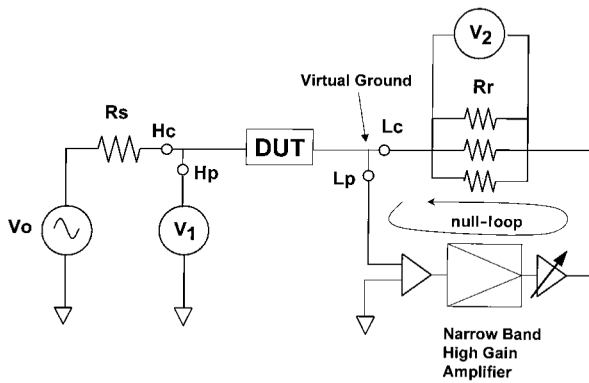

Figure 1. Circuit diagram of the Auto-Balancing-Bridge method

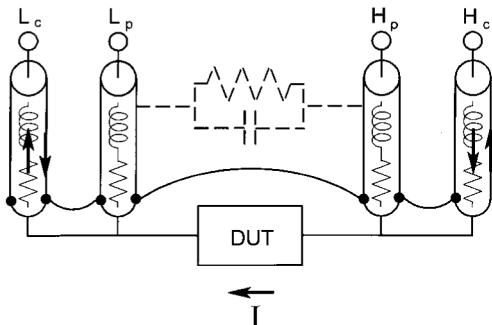

Figure 2. Four-Terminal-Pair cabling technique

The null amplifier consists of an input amplifier, a narrow-band, high-gain amplifier, and an output amplifier. This circuit maintains the virtual ground at the Lp terminal, and pulls the current to a range resistor. By detecting the voltage of the range resistors, the current, which flows through the DUT, is measured. Impedance analyzers usually have several range resistors in order to achieve high-resolution for various current measurements. With the technology of this feedback loop, the cabling method called a Four-Terminal-Pair (4TP) configuration is used. This configuration minimizes error factors that exist in the measurement path. (See Figure 2.) The “measurement path” refers to the path from the voltage/current measuring circuit in the instrument to the DUT connection. The 4TP configuration removes influences such as the series residual impedance of a cable, stray capacitance between cables, and mutual inductance of cables. With this configuration, a wide range of impedance can be measured from low-Z to high-Z. Figure 3 shows the circuit diagram of the latest Auto-Balancing-Bridge technology. The signal generated by a signal source will flow in a circuit. This technology can provide the most accurate measurements through the use of the Auto-Balancing-Bridge technique with the Four-Terminal-Pair configuration.

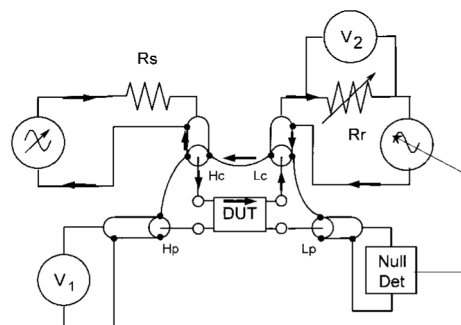

Figure 3. Combination of the Auto-Balancing-Bridge technique with the Four-Terminal-Pair configuration

#### 4. Problems with Previous Auto-Balancing-Bridge Technique

The Auto-Balancing-Bridge method is an exceptional technology, but there were some technical barriers that made it difficult to extend the frequency range or to improve the measurement accuracy.

##### Technical Barrier No. 1: The bridge circuit cannot balance when the frequency is too high or when the cable length is too long.

When the frequency is too high, a standing wave occurs in the measurement path under certain conditions. These conditions are determined by the measurement path-length and the signal wavelength. In certain cases, the bridge circuit cannot balance. The first case is when the measurement path is equal to 1/4 of the signal wavelength. For example, 1/4 wavelength of 100 MHz is about 75 cm. At this frequency, a standing wave occurs and the bridge circuit cannot balance. If a 1-m cable (or longer) is used, the standing wave occurs during a swept measurement, because during the sweep there will be one wavelength that coincides with the measurement path-length. Again, the bridge cannot balance under this condition. To avoid this problem, the frequency range of the 4194A was limited to 15 MHz, when using a 1-m cable. The solution to this problem is related to the way that

**Table 2. Each terminal's role in the Auto-Balancing-Bridge circuit**

Terminal	Function
Lp	Detects the voltage between the inner conductor and the outer conductor.  Balances the bridge circuit by feeding the detected voltage back to the instrument.
Lc	Detects the current, which flows from the inner conductor to the outer conductor. (This becomes the measured current value.)
Hp	Detects the voltage between the inner conductor and the outer conductor. (This becomes the measured voltage value.)
Hc	Outputs the signal from the signal source and applies it to the DUT.

the circuit behaves and the reason the bridge cannot balance. Figure 4 is a diagram of the ABB technique, which clearly shows the measurement path.

In an LF measurement, the signal-levels at both ends of the measurement path are observed to be the same for the lower frequencies. As the frequency increases, the signal levels at each end of the measurement path begin to diverge. As discussed earlier, the standing wave is a phenomenon resulting from the equality of the measurement path-length and wavelength of the test-signal. Note that this can occur in each of the four measurement paths individually.

Table 2 shows the role of each of the four terminals. The feedback loop around the Lp terminal maintains the virtual ground. Therefore, if a standing wave occurs in the Lp measurement path, the Lp terminal cannot control the potential difference between the inner and the outer conductors. The result is that the bridge circuit loses balance.

Since the voltage of the Lp outer conductor is influenced by the flow of current (see Figure 3), a standing wave occurring at the Lc, or Hc terminal will also make the bridge circuit unstable. Each of these terminals plays a role in measurement, so if the bridge is unstable, each of these values will become unstable, even if the bridge is somehow balanced.

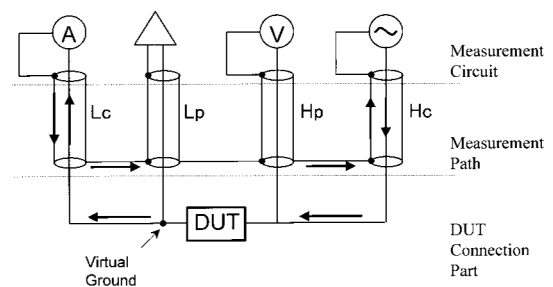

**Figure 4. Auto-Balancing-Bridge method and measurement path**

**Technical Barrier No. 2: Impedance measurement range is limited due to the noise level and spurious characteristics in the instrument circuit.**

For both high and low impedance measurements, the instrument noise level affects the measurement performance. If the noise level is high, the impedance measurement range will become narrower. Recently, there are requirements to measure impedance at less than 10 m $\Omega$  and more than 100 k $\Omega$ . Previous instruments did not cover such a wide impedance range. Impedance analyzers with the capability to perform swept measurements use more complicated circuits than LCR meters, so it has been difficult to keep the noise-level low in the impedance analyzer circuit, as was possible with LCR meters. The noise level can be easily observed by measuring the open or short impedance. Naturally, if the short measurement value is about 10 m $\Omega$ , it is impossible to measure below 10 m $\Omega$ . The main factors to be considered when determining the noise level of the measurement circuit are the spurious characteristics, noise, offset level of the narrow-band high-gain amplifier (the heart of the null-loop), and the noise and spurious characteristics of the signal source. (See Figure 1.)

**Technical Barrier No. 3: When making sensitive D (dissipation factor) or Q (quality factor) measurements, the measurement value becomes unstable when the measurement range changes.**

Auto-Balancing-Bridge instruments have several range resistors that precisely detect current. In Figure 1, the current at the Lc terminal routes to one of a set of range resistors, where the current can be determined by measuring the voltage across the respective range resistor. To cover a wide impedance range, the instrument needs to measure a wide range of current values. Therefore, each range resistor is rated to correspond with certain ranges of current. For precision measurement, each range resistor must be precisely adjusted. Previously, each range resistor was adjusted using individual impedance standards. This caused differences in measured values for different measurement ranges. Though the measurement results were still within the measurement specification of the instrument, sensitive measurements, such as low-D or high-Q measurements, were often very difficult to obtain.

## 5. Agilent 4294A Solution No. 1: Frequency Expansion

The 4294A is an impedance analyzer, which has a wide frequency range (40 Hz to 110 MHz) and extremely accurate measurement capabilities. It employs the most accurate measurement technique (Auto-Balancing-Bridge) and has successfully extended the frequency range of this technique. The circuit diagram shown in Figure 1 is basically the same as the circuit used in the 4294A, however, recent technical improvements have been made to resolve the problems described in Chapter 4. The differences between the recently improved technique and previous techniques are explained in Chapters 5 and 6. Technical barrier no. 1 (see Chapter 4) was solved as follows:

### 1. Cable terminated Auto-Balancing-Bridge method

The 4294A uses an innovative technology called “Cable terminated Auto-Balancing-Bridge method.” The circuit diagram is shown in Figure 5. To solve the problem of a standing-wave at high frequency, the measurement path is terminated by the characteristic impedance of the cable ( $50 \Omega$ ). With this termination, the measurement signal can be precisely conveyed, independent of the frequency or the path-length. This solves all problems caused in the measurement path, such as the bridge balance issue (at  $L_p$ ), a voltage/current level detection issue at  $H_p$  and  $L_c$ , and an applied signal level issue at  $H_c$ .

With this innovation, the frequency range of the 4294A has been successfully extended, while maintaining the existing features (high accuracy and wide impedance range). This technology has a great benefit in the higher frequency range, and is utilized above 15 MHz, when no cable extension is used. It can also be used above 5 MHz when a 1-m or 2-m cable extension is used.

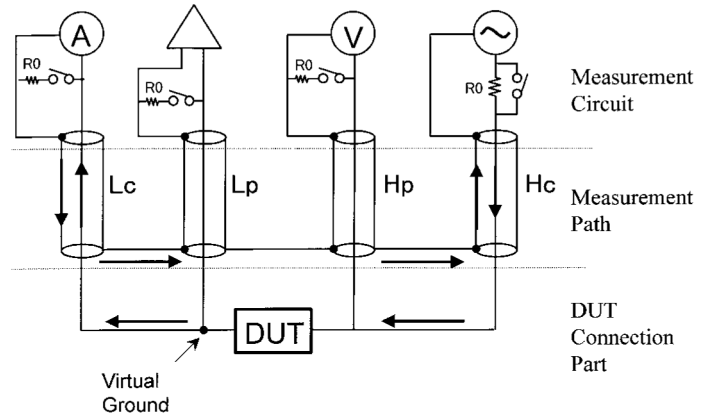

Figure 5. Cable Terminated Auto-Balancing-Bridge method

## 2. Bridge Stability Improvement by Phase Adjustment

As one more solution to address technical barrier no. 1 (the bridge balance problem at higher frequencies), the 4294A has a special circuit designed to compensate for the null-loop characteristics, which can vary with frequency and cable length. The circuit diagram is shown in Figure 6. In the null-loop circuit, the vector voltmeter ( $V\phi$ ) and local oscillator ( $E\phi$ ) are respectively placed before and after the narrow-band, high-gain amplifier.

The null-loop circuit characteristics can be measured by performing the following procedure:

- Connect the  $L_p$  and  $L_c$  terminals.
- Supply a signal from the signal source  $E\phi$  clockwise through the null-loop circuit. (See Figure 6.) Measure  $V\phi$ .

The data is saved in internal memory and is used to achieve a stable balance of the bridge circuit when a measurement is made. This data indicates voltage of both  $E\phi$  and  $V\phi$ , and is measured over the entire frequency range; so repetition of the second and third steps (above) is required to compile all the data.

The phase adjustment is performed in the factory before shipment, and regularly during calibration. In the cable compensation procedures (used during normal operation), this adjustment is performed prior to extending the measurement port. Because each cable has different characteristics, it is particularly important to perform this procedure during cable compensation. This function can be performed on the instrument's front panel when performing cable compensation.

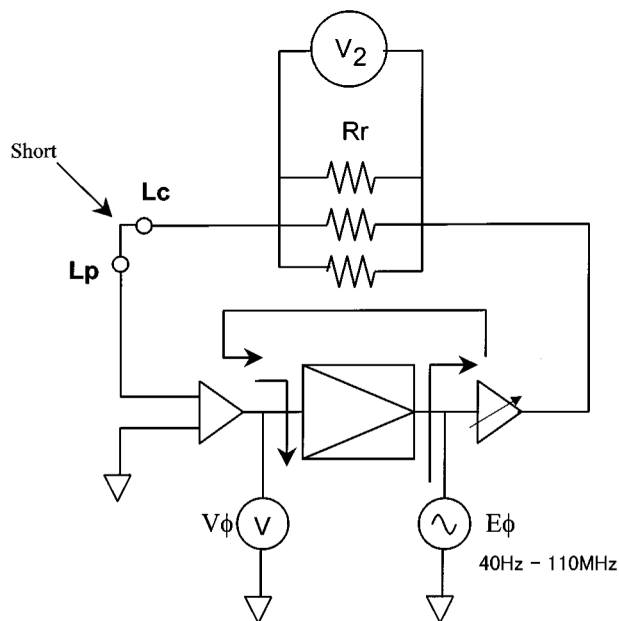

Figure 6. Bridge stability improvement by phase adjustment

## 6. 4294A Solution No. 2: Impedance/Phase Accuracy Improvements

The impedance and phase measurement accuracy of the Auto-Balancing-Bridge technique was improved by resolving technical barriers nos. 2 and 3, as described in Chapter 4.

### 1. Low noise circuit design

Circuit noise in the Agilent 4294A has been minimized through a careful and thorough circuit design process, which included attention to circuit board traces, alignment of components on the boards and selection of components. For example, a high-performance signal source was used to ensure that noise and spurious characteristics were minimized. Also, the characteristics of the narrow-band, high-gain amplifier (in the null-loop) were dramatically improved by minimizing noise, spurious characteristics, and offset level. This decreased the equivalent, converted input noise of the null amplifier.

### 2. Calibration Using a Single External Reference

As described in Chapter 4, the previous Auto-Balancing-Bridge technique required that each range resistor be adjusted using individual impedance standards. The 4294A uses a special adjustment technique in which all ranges are adjusted with a single external reference. This new technique overcomes technical barrier no. 3. The 4294A has four range resistors in total (50  $\Omega$ , 400  $\Omega$ , 3.2 k $\Omega$  and 25.6 k $\Omega$ ). The adjustment is performed according to the following procedure:

- Compensate relative differences between neighboring range resistors by measuring the internal “reference resistors.” (The 4294A has four internal reference resistors.)
- Measure the external reference (100  $\Omega$ ). The absolute adjustment for all ranges is performed using this reference.

This adjustment method brings great benefit to impedance measurements (particularly sensitive D or Q measurements), which can drastically vary according to the measurement frequency. Also,

during regularly scheduled service (adjustment and calibration) this method improves adjustment efficiency. These improvements give the 4294A expanded impedance and phase measurement capabilities compared with previous impedance analyzers. Figure 7 shows the results of open and short measurements. These measurement results show the limitation when measuring higher and lower impedance values. The open measurement capability has been extended from about 1 G $\Omega$  (Agilent 4194A) to about 10 G $\Omega$  (Agilent 4294A). The short measurement capability has been extended from about 1 m $\Omega$  (4194A) to about 0.1 m $\Omega$  (4294A). This means that the upper and lower impedance measurement ranges have each been expanded by an order of magnitude.

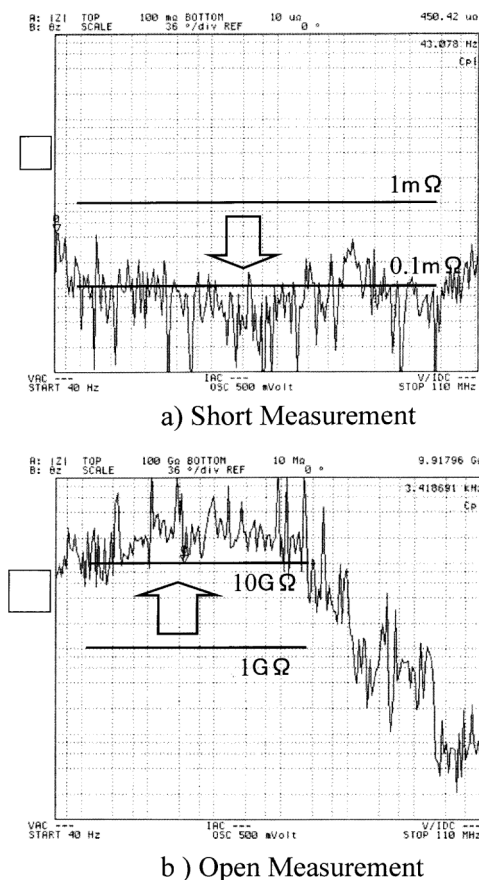

**Figure 7. OPEN/SHORT measurement limitations of the 4294A (reference data)**



In addition, the phase measurement capability has also been improved. Figure 8 shows the quality factor (Q) measurement accuracy of the 4194A compared to the 4294A (Q of 100). The 4294A can maintain 10% accuracy or better in the lower frequencies (100 Hz to 10 MHz). Formerly, the Agilent 42851A (resonant method) was widely used for accurate Q measurement. The improved accuracy of the 4294A enables Q measurement with the same level of reliability as with the 42851A. Table 3 and Figure 9 show a comparison of a Q measurement result when using these instruments. The upper graph shows the actual results, while the lower graph shows the percentage difference between these measurement results, and demonstrates good correlation. The operation of the 4294A is much easier than that of the 42851A, and so the 4294A is highly recommended for Q measurement.

**Table 3. Instrument state for Q measurement**

	4294A	4285A + 42851A
<b>Test frequency measured DUT</b>	1 MHz: 16480A (100 $\mu$ H) 2.5 MHz: 16481A (56 $\mu$ H) 4 MHz: 16483A (10 $\mu$ H) 7.9 MHz: 16485A (2.5 $\mu$ H) 10 MHz: 16485A (2.5 $\mu$ H) 22 MHz: 16486A (1 $\mu$ H) 30 MHz: 16488A (0.28 $\mu$ H)	
<b>Test fixture</b>	<b>42942A, 16093B</b>	<b>None</b>
<b>Fixture compensation</b>	Adapter setup on 42942A Electrical length 3.4 mm OPEN/SHORT compensation on 16093B using 16193B shorting device	Short compensation

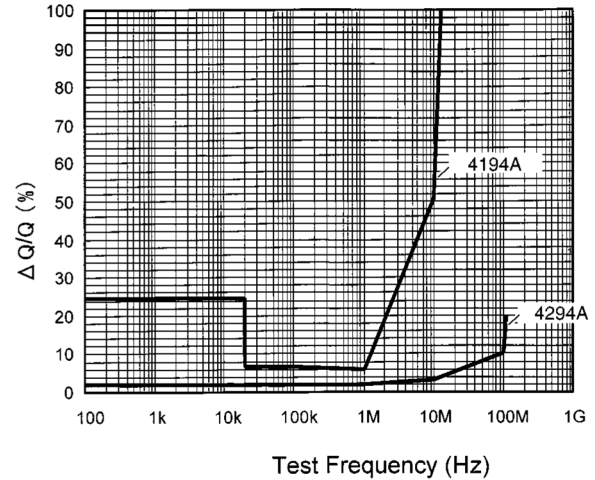

**Figure 8. 4294A/4194A Q measurement error (reference data)**

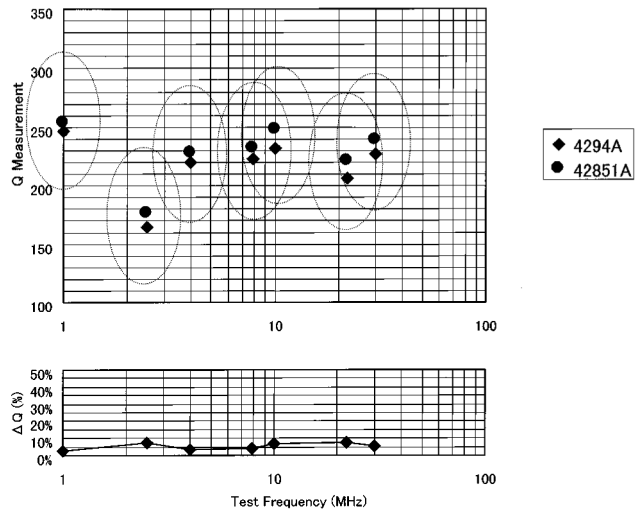

**Figure 9. Q measurement with the 4294A and the 42851A**

## 7. Other New Technology—1: New Impedance Probe

The Agilent 42941A impedance probe provides probe measurement capability to the 4294A. The technology used is different from the previous IV method, resulting in successful expansion of the frequency range as well as the impedance measurement range. There were two main technical difficulties when developing this solution.

1. The previous I-V method used a transformer to “pick-up” the current, however this method resulted in large losses, and was not suitable for detection of small currents.
2. The frequency range was limited by the transformer’s operational frequency range. With the 42941A impedance probe, a new technology called the “Advanced I-V Method” was introduced. Figure 10 shows a comparison of the circuit diagrams used in these methods.

The differences between the previous I-V method and the new IV method are as follows:

1. With the new method, a nearly ideal current meter is used, without the need for a transformer. This enables accurate measurement of small current. The result is the enhancement of the ability to measure high-impedance. The null-loop circuit of the 4294A is used as a current meter.
2. No transformer is used in the “Advance I-V Method,” so the operational frequency range of this solution is not dependent on the performance of a transformer. This is of particular importance in the lower frequency range, where the 4194A + 41941A was limited to a minimum of 10 kHz, the 4294A + 42941A is limited to a minimum of 40 Hz.

Figure 11 shows the typical 10% measurement accuracy range of the 42941A compared to that of the 41941A. This clearly shows that the 42941A has a much wider frequency range and a much wider impedance measurement range than was possible with the 41941A. The 42941A expansion of this probing methodology made possible a variety of new applications.

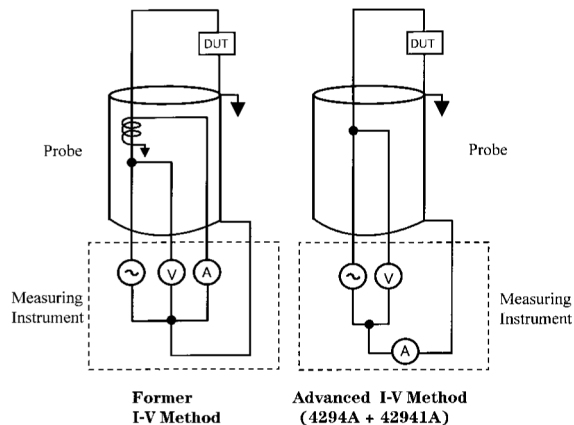

**Figure 10. Circuit diagrams of the 42941A impedance probe and the previous 41941A impedance probe**

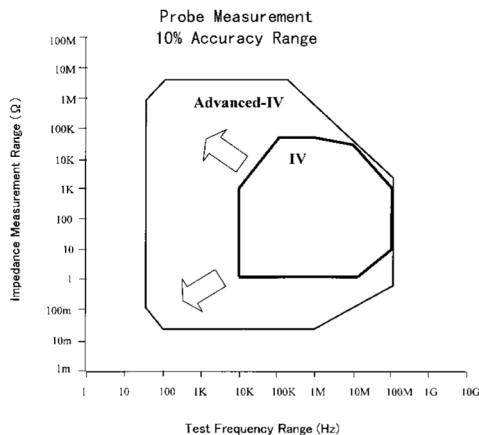

**Figure 11. 10% measurement accuracy range of the 42941A and the 41941A**

## 8. Other New Technology—2: 7-mm Connector Adapter

The Agilent 42942A adapter is used to convert the Four-Terminal-Pair configuration into a 7-mm test port. This allows for the connection of 7-mm test fixtures to the Four-Terminal-Pair configuration of the 4294A. This adapter has incorporated design changes that reduce the effects of external noise on measurements. Figure 12 shows the difference between the 16085B and the 42942A. In the 16085B, the current flows through the DUT, then through the adapter's outer conductor. It is measured by the current meter of the instrument. In this case, the external noise, received in the adapter's outer conductor, influences measurement results. In the 42942A, the current meter is positioned at the high terminal so that only the current which flows through the DUT is measured. Note that this technology is realized with the combination of the 4294A and the 42942A. This does not mean that the same technology can be obtained with the combination of older instruments and the 42942A.

## 9. Other New Technology—3: Cable Extension

With the 4294A, a 2-m cable can be used at frequencies as high as 110 MHz. This is an innovative technology, since previous ABB impedance analyzers were limited to a maximum cable length of 1 m at a maximum frequency of 15 MHz. Table 4 lists the cable extension capability of impedance analyzers. This enhancement is realized by the technical improvement explained in Chapter 5 (the bridge balance stability improvement). Since the accuracy at the end of a cable is guaranteed for those cable lengths described in Table 4 (for cables 16048G/H), it is much easier to integrate the 4294A into a system.

**Table 4. Cable extension function of Agilent impedance analyzers**

Model	Cable length	Frequency upper limit
4294A	0 m, 1 m, 2 m	110 MHz
4194A	0 m, 1 m	15 MHz
4192A	0 m, 1 m	13 MHz

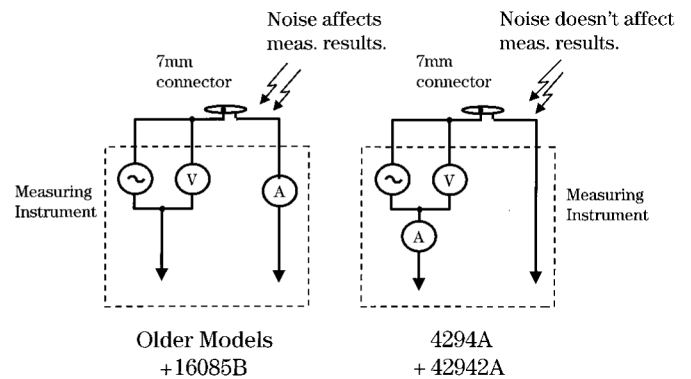

**Figure 12. Enhancing 7-mm adapter technology**

## 10. Comparison of the Latest Impedance Measurement Techniques

With the frequency expansion of the Auto-Balancing-Bridge method, the impedance measurement technology map has been drastically changed. Figure 13 shows the 10% measurement accuracy range of each technique.

The upper frequency limit of the Auto-Balancing-Bridge method has been extended from 40 Hz to 110 MHz. This means that the previous I-V method area can be replaced by the Auto-Balancing-Bridge method. Then, this technique's advantage (wide impedance coverage and high accuracy) is obtained in this frequency range. On the other hand, the I-V method is required for in-circuit probing measurements and grounded device measurements. With the advanced I-V method, the frequency range and the impedance coverage are powerfully improved.

## 11. Summary

The Agilent 4294A is the impedance analyzer with a wide frequency range, broad impedance coverage, and accurate measurement capability. It provides the world's best performance in any impedance measurement between 40 Hz and 110 MHz. Together with the 4291B (1.8-GHz impedance/material analyzer), Agilent Technologies' impedance analyzers fit all impedance measurement applications.

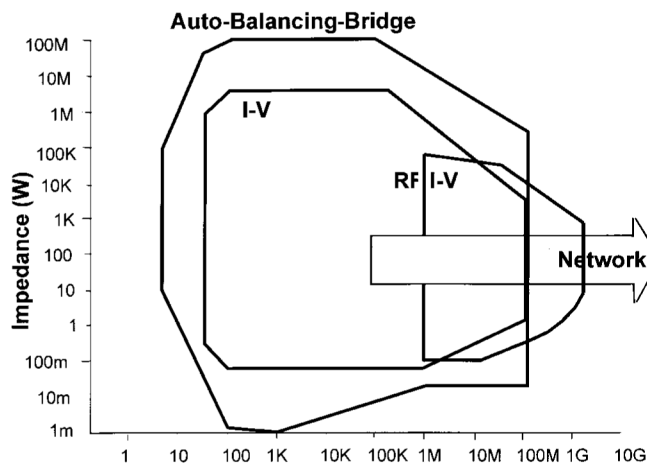

Figure 13. Comparison chart of impedance measurement techniques

### Agilent Technologies' Test and Measurement Support, Services, and Assistance

Agilent Technologies aims to maximize the value you receive, while minimizing your risk and problems. We strive to ensure that you get the test and measurement capabilities you paid for and obtain the support you need. Our extensive support resources and services can help you choose the right Agilent products for your applications and apply them successfully. Every instrument and system we sell has a global warranty. Support is available for at least five years beyond the production life of the product. Two concepts underlie Agilent's overall support policy: "Our Promise" and "Your Advantage."

#### Our Promise

"Our Promise" means your Agilent test and measurement equipment will meet its advertised performance and functionality. When you are choosing new equipment, we will help you with product information, including realistic performance specifications and practical recommendations from experienced test engineers. When you use Agilent equipment, we can verify that it works properly, help with product operation, and provide basic measurement assistance for the use of specified capabilities, at no extra cost upon request. Many self-help tools are available.

#### Your Advantage

"Your Advantage" means that Agilent offers a wide range of additional expert test and measurement services, which you can purchase according to your unique technical and business needs. Solve problems efficiently and gain a competitive edge by contracting with us for calibration, extra-cost upgrades, out-of-warranty repairs, and on-site education and training, as well as design, system integration, project management, and other professional services. Experienced Agilent engineers and technicians worldwide can help you maximize your productivity, optimize the return on investment of your Agilent instruments and systems, and obtain dependable measurement accuracy for the life of those products.

Get assistance with all your test and measurement needs at: [www.agilent.com/find/assist](http://www.agilent.com/find/assist)

Product specifications and descriptions in this document subject to change without notice.

Copyright © 1999, 2000 Agilent Technologies  
Printed in U.S.A. 11/00  
5968-4506E



**Agilent Technologies**

Innovating the HP Way